

LM3658 Evaluation Kit

National Semiconductor
Application Note 1517
Rich Dye
October 2006



LM3658 Overview

The LM3658 is a single chip charger IC designed for handheld applications. LM3658 can safely charge and maintain a single cell Li-Ion/Polymer battery operating off an AC wall adapter or the USB power (VBUS). Input power source selection of USB/AC is automatic. With both power sources present, the AC power source has priority. Charge current is programmed through an external resistor when operating from a wall AC adapter allowing charge currents from 50 mA to 1000 mA. When the battery is charged using USB power, charge currents of 100 mA or 500 mA are pin selectable. The termination voltage is controlled to within $\pm 0.35\%$ of 4.2V. The LM3658 requires few external components and integrates internal Power FETs, reverse current protection and current sensing. The internal power FETs are thermally regulated to obtain the most efficient charging rate for a given ambient temperature.

The LM3658 operates in five phases: pre-qualification mode, constant-current mode, constant-voltage mode, toff mode and maintenance mode. Additionally, the LM3658-B charger IC operates as a linear Regulator or in "LDO mode" when the AC wall adapter is connected and no battery is present. Optimal battery management is obtained through the integration of thermal protection, battery temperature measurement and a multi-mode safety timer. The LM3658 provides two open-drain outputs for LED status indication or connection to a GPIO.

For more information, please refer to the LM3658 datasheet.

Jumper Functions

The following table describes the functionality associated with each jumper found on the LM3658 eval board.

Jumper name	Default position	Jumper Functionality
R8	Jumper in place	Connects 10 k Ω from T _S to GND pins
R7	Jumper in place	Connects 5 k Ω from I _{SET} to GND pins
R6	Open	Connects 10 k Ω from I _{SET} to GND pins
R5	Open	Connects 25 k Ω from I _{SET} to GND pins
BATT	Jumper in place	Provides LED bias from BATT pin
CHG-IN	Open	Provides LED bias from CHG-IN pin
EN	Jumper in place	Shorts EN_b pin to GND, enabling charging
DISBL	Jumper to CHG-IN	Connects EN_b pullup resistor to CHG-IN or USB _{PWR}
I _{USB}	Jumper in place	Shorts USB_sel to GND, setting USB current to 90 mA

Evaluation Kit Overview

LM3658 evaluation kit supports complete functional evaluation of the battery charger IC. All user accessible functions of the circuit can be controlled through jumpers. The evaluation kits are available in three options: LM3658SDEV, LM3658SD-AEV, and LM3658SD-BEV. For detail of the various options, please refer to order information table.

Getting Started

The following instructions show how to use the LM3658 evaluation kit. Please use the ESD protection (ground cable) to prevent any unwanted damaging ESD events.

1. Connect a power supply (4.5V to 6.0V) to the "CHG-IN" and the "GND" pins. Power supply's negative terminal should be connected to "GND" and positive to "CHG-IN." Alternatively, power supply can be connected to the "USBpwr" pin and the "GND" pin.
2. Connect a Li-Ion battery pack to "BATT" and "GND" pins. The battery pack's negative terminal should be connected to "GND" and positive to "BATT."
3. Check to make sure that "EN_b" pin has a jumper in place. This pulls the pin low, enabling the LM3658.
4. Check to make sure there is a jumper in place for R7. R7 is a 5 k Ω resistor connected to the "I_{SET}" pin which will program the full-rate charge current to 500 mA.
5. Check to make sure there is a jumper in place for R8. This jumper connects a 10 k Ω resistor across the "T_S" pin and the "GND" pin.
6. The evaluation board is now ready for operation. Turning on the power supply will start the charge cycle if battery is not fully charged.

Detailed Operation of the Evaluation Board

The LM3658 is capable of accepting charge from either an AC adaptor or a USB port. When both are connected at the same time, the LM3658 will choose the AC adaptor as the power source.

CHARGING FROM AC ADAPTOR

When the LM3658 is accepting charge from the AC adaptor, the “I_{SET}” pin is used to program the full-rate charge current. On the evaluation board, there is space for three separate external resistors, providing up to seven different selections for charge current. Charge current can be calculated using this equation:

$$I_{\text{CHG}} = \frac{K_{\text{ISET}}}{R_{\text{ISET}}}$$

20204402

Where K_{ISET} = 2500. The evaluation board is assembled with the following resistors.

I _{SET} Resistor	Value (kΩ)	Charge Current (mA)
R5	25	100
R6	10	250
R7	5	500

CHARGING FROM USB PORT

When the LM3658 is accepting charge from the USB port, the “USB_sel” pin sets the full-rate charge current, not the “I_{SET}” pin. Pulling the “USB_sel” pin low will set the charge current to 100 mA; pulling this pin high will set it to 500 mA. On the LM3658 evaluation board, a 10 kΩ resistor pulls this pin high to the “USB_{PWR}” voltage. By placing a jumper on I_{USB}, the pin is pulled low to ground.

ENABLING/DISABLING THE LM3658

The “EN_b” pin is used to enable and disable the LM3658. Pulling this pin low by placing a jumper on EN enables the LM3658. Pulling this pin high through the 10 kΩ resistor to the “CHG-IN” voltage disables the LM3658 on the evaluation board.

STAT-1 AND STAT-2 INDICATORS

The LM3658 has two open-drain outputs to indicate the charge status of the LM3658, as shown below:

STAT-1 (CHG)	STAT-2 (EOC)	Condition
Off	Off	Power-down, charging is suspended or interrupted
On	Off	Pre-qualification mode, CC and CV charging
Off	On	Charge is completed
On	On	Bad battery (Safety timer expired) or LDO mode

These two outputs can be connected to LEDs or to General Purpose I/Os (GPIO). On the LM3658 evaluation board, STAT-1 is connected to a red LED and STAT-2 is connected to a green LED.

BATTERY TEMPERATURE MONITORING

The LM3658 is equipped with a battery thermistor interface to continuously monitor the battery temperature by measuring the voltage between the T_S pin and ground. Internal to the LM3658 are two comparators that set an upper limit of 2.5V and a lower limit of 0.5V in which charging is allowed. If the voltage at T_S pin is outside of this window, charging is suspended. On the LM3658 evaluation board, the T_S pin is connected to a 10 kΩ resistor.

LDO MODE OF THE LM3658-B

By removing the 10 kΩ resistor and leaving the T_S pin floating, the LM3658-B assumes there is no battery present and goes into LDO mode if CHG-IN pin is connected to an AC adaptor. In LDO mode, the LM3658 provides up to 1A of current at BATT pin. The LDO mode is not possible when operating from the USB_{PWR} input. The jumper located next to R8 can be removed to observe the LDO mode function on the LM3658-B eval board. Note that removing the R8 jumper on the LM3658 and LM3658-A eval board causes an effective battery overtemperature condition and the charge current will turn off.

LM3658 Evaluation Board Schematic

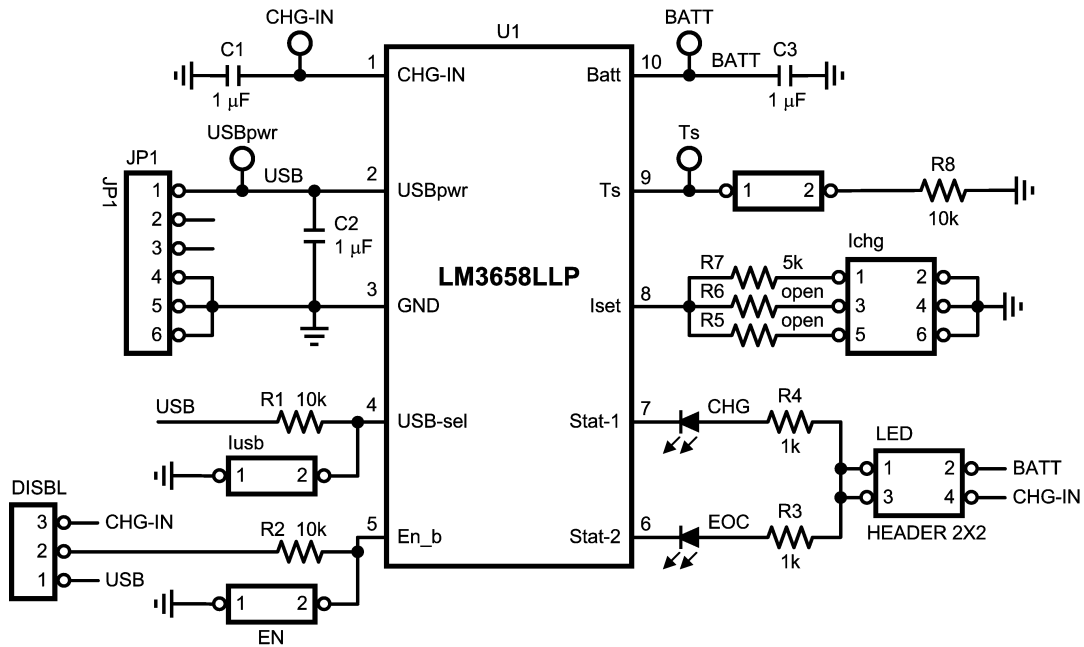

20204401

Ordering Information

Order Number	5 Hour Timer	Selectable Timer	LDO Mode	No LDO Mode	Package Marking	Supplied As
LM3658SD	X			X	L111B	1000 units, TNR
LM3658SDX	X			X	L111B	4500 units, TNR
LM3658SD-A		X		X	L155B	1000 units, TNR
LM3658SDX-A		X		X	L155B	4500 units, TNR
LM3658SD-B	X		X		L156B	1000 units, TNR
LM3658SDX-B	X		X		L156B	4500 units, TNR

Bill of Material for LM3658 Evaluation Board

Designator	Description	Footprint	Comment
C1, C2, C3	1 μF, ceramic	0805	TDK
R1, R2, R8	10kΩ	0805	Vishay
R3, R4	1kΩ	0805	Vishay
R5	25kΩ	0805	Vishay
R6	10kΩ	0805	Vishay
R7	5kΩ	0805	Vishay
CHG	Red LED	0805 2x	Vishay TLMT3100
EOC	Green LED	0805 2x	Vishay TLMC3100
JP1	USB Connector		Not assembled
I _{USB} , DISBL, EN, LED, I _{CHG}	Headers		
CHG_IN, USB _{PWR} , BATT, T _S , GND	Contact posts		
U1	LM3658SD or LM3658SD-A or LM3658SD-B	SDA10A	National Semiconductor

Notes

National does not assume any responsibility for use of any circuitry described, no circuit patent licenses are implied and National reserves the right at any time without notice to change said circuitry and specifications.

For the most current product information visit us at www.national.com.

LIFE SUPPORT POLICY

NATIONAL'S PRODUCTS ARE NOT AUTHORIZED FOR USE AS CRITICAL COMPONENTS IN LIFE SUPPORT DEVICES OR SYSTEMS WITHOUT THE EXPRESS WRITTEN APPROVAL OF THE PRESIDENT AND GENERAL COUNSEL OF NATIONAL SEMICONDUCTOR CORPORATION. As used herein:

1. Life support devices or systems are devices or systems which, (a) are intended for surgical implant into the body, or (b) support or sustain life, and whose failure to perform when properly used in accordance with instructions for use provided in the labeling, can be reasonably expected to result in a significant injury to the user.
2. A critical component is any component of a life support device or system whose failure to perform can be reasonably expected to cause the failure of the life support device or system, or to affect its safety or effectiveness.

BANNED SUBSTANCE COMPLIANCE

National Semiconductor follows the provisions of the Product Stewardship Guide for Customers (CSP-9-111C2) and Banned Substances and Materials of Interest Specification (CSP-9-111S2) for regulatory environmental compliance. Details may be found at: www.national.com/quality/green.

Lead free products are RoHS compliant.



National Semiconductor
Americas Customer
Support Center
Email: new.feedback@nsc.com
Tel: 1-800-272-9959

www.national.com

National Semiconductor
Europe Customer Support Center
Fax: +49 (0) 180-530 85 86
Email: europa.support@nsc.com
Deutsch Tel: +49 (0) 69 9508 6208
English Tel: +44 (0) 870 24 0 2171
Français Tel: +33 (0) 1 41 91 8790

National Semiconductor
Asia Pacific Customer
Support Center
Email: ap.support@nsc.com

National Semiconductor
Japan Customer Support Center
Fax: 81-3-5639-7507
Email: jpn.feedback@nsc.com
Tel: 81-3-5639-7560